

# MX4-32 Bare Pump Assemblies

Models: 0115-010000 (PTFE/LEATHER CHEVRONS), 0115-010000-P (PTFE CHEVRONS), 0115-010234 (UHMW U-CUPS)

Patent Pending

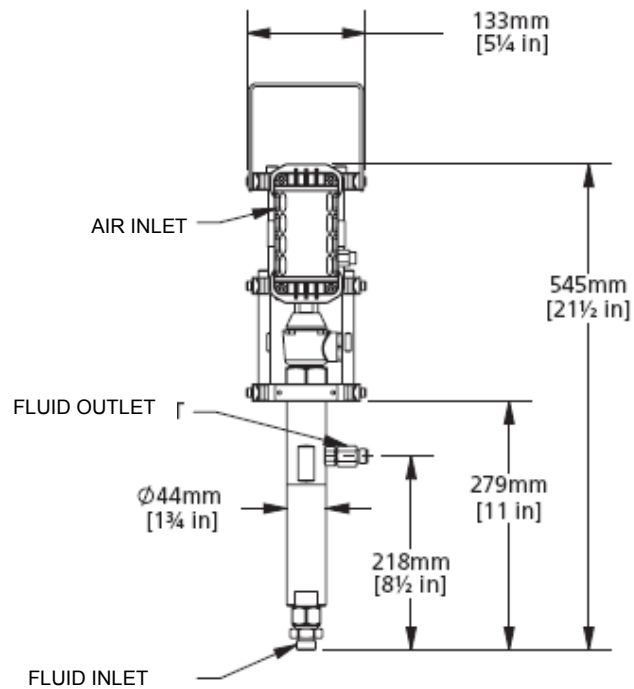
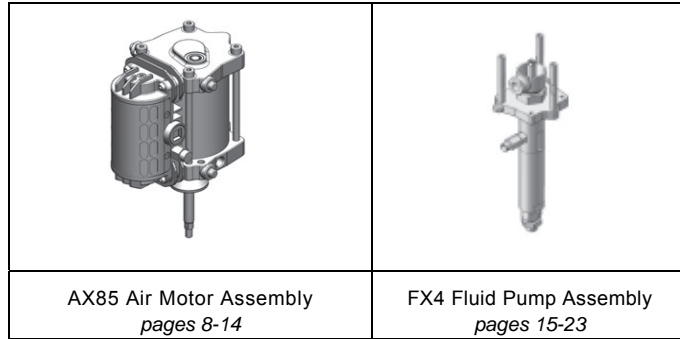
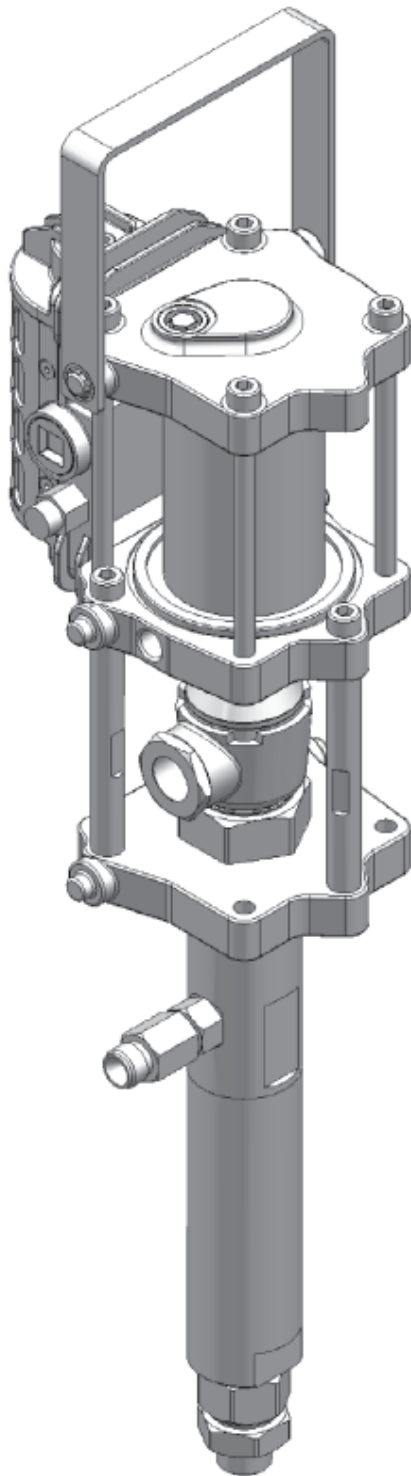

<b>SPECIFICATIONS</b>	
Ratio:	32:1
Maximum air inlet pressure:	8 bar [116 psi]
Maximum fluid pressure:	256 bar [3712 psi]
Displacement per cycle:	24 cc [0.8 oz]
Output @ 60 cycles/min:	1.4 L/m [0.4 gal/m]
Maximum recommended continuous cycle rate:	20 cycles/min
Air inlet connection:	3/8" BSP(f)
Fluid inlet connection:	1/2" NPS(m)
Fluid outlet connection:	3/8" BSP(m) and 3/8" NPS(m)
Weight:	7 kg [15.4 lbs]

In this part sheet, the words **WARNING**, **CAUTION** and **NOTE** are used to emphasize important safety information as follows:

<b>WARNING</b>	<b>CAUTION</b>	<b>NOTE</b>
Hazards or unsafe practices which could result in severe personal injury, death or substantial property damage.	Hazards or unsafe practices which could result in minor personal injury, product or property damage	Important installation, operation or maintenance information

**WARNING**

Read the following warnings before using this equipment.



**READ THE MANUAL**

Before operating finishing equipment, read and understand all safety, operation and maintenance information provided in the operation manual.



**WEAR SAFETY GLASSES**

Failure to wear safety glasses with side shields could result in serious eye injury or blindness.



**DE-ENERGIZE, DEPRESSURIZE, DISCONNECT AND LOCK OUT ALL POWER SOURCES DURING MAINTENANCE**

Failure to De-energize, disconnect and lock out all power supplies before performing equipment maintenance could cause serious injury or death.



**OPERATOR TRAINING**

All personnel must be trained before operating finishing equipment.



**EQUIPMENT MISUSE HAZARD**

Equipment misuse can cause the equipment to rupture, malfunction, or start unexpectedly and result in serious injury.



**KEEP EQUIPMENT GUARDS IN PLACE**

Do not operate the equipment if the safety devices have been removed.

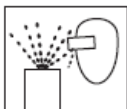

**PROJECTILE HAZARD**

You may be injured by venting liquids or gases that are released under pressure, or flying debris.



**PINCH POINT HAZARD**

Moving parts can crush and cut. Pinch points are basically any areas where there are moving parts.



**AUTOMATIC EQUIPMENT**

Automatic equipment may start suddenly without warning.



**INSPECT THE EQUIPMENT DAILY**

Inspect the equipment for worn or broken parts on a daily basis. Do not operate the equipment if you are uncertain about its condition.



**NEVER MODIFY THE EQUIPMENT**

Do not modify the equipment unless the manufacturer provides written approval.



**KNOW WHERE AND HOW TO SHUT OFF THE EQUIPMENT IN CASE OF AN EMERGENCY**



**PRESSURE RELIEF PROCEDURE**

Always follow the pressure relief procedure in the equipment instruction manual.



**NOISE LEVELS**

The A-Weighted sound level of pumping equipment and spray guns may exceed 85 dB (A) depending on the set-up being used. Details of actual noise levels are available on request. It is recommended that ear protection is worn at all times when spraying while pump is operating.



**HIGH PRESSURE CONSIDERATION**

High pressure can cause serious injury. Relieve all pressure before servicing. Spray from the spray gun, hose leaks, or ruptured components can inject fluid into your body and cause extremely serious injury.



**STATIC CHARGE**

Fluid may develop a static charge that must be dissipated through proper grounding of the equipment, objects to be sprayed and all other electrically conductive objects in the dispensing area. Improper grounding or sparks can cause a hazardous condition and result in fire, explosion or electric shock and other serious injury.

**IT IS THE RESPONSIBILITY OF THE EMPLOYER TO PROVIDE THIS INFORMATION TO THE OPERATOR OF THE EQUIPMENT.**

**FOR FURTHER SAFETY INFORMATION REGARDING BINKS AND DEVILBISS EQUIPMENT, SEE THE GENERAL EQUIPMENT SAFETY BOOKLET (77-5300).**

## ⚠ WARNING



**HIGH PRESSURE CAN CAUSE SERIOUS INJURY IF EQUIPMENT IS INSTALLED OR USED INCORRECTLY—READ, UNDERSTAND, AND OBSERVE ALL WARNINGS AND INSTRUCTIONS IN THIS MANUAL.**

**INSTALL, OPERATE OR SERVICE THIS EQUIPMENT ONLY AFTER ALL INSTRUCTIONS ARE CLEARLY UNDERSTOOD.**

**It is the responsibility of the employer to place this information into the hands of the operator.**

<b>⚠ WARNING</b>	<b>⚠ CAUTION</b>	<b>NOTE</b>
Hazards or unsafe practices which could result in severe personal injury, death or substantial property damage.	Hazards or unsafe practices which could result in minor personal injury, product or property damage	Important installation, operation or maintenance information

### AVOID STATIC SPARKING

1. Use Binks **NO-WIRE** conductive hose in all airless spraying operations. Be sure the gun and hose have continuity.
2. Make sure the pump is grounded. **NEVER** operate the unit when it is on a non-grounded platform.
3. When flushing or cleaning with a combustible solvent, always use an open metallic container for receiving the waste solvent. Ground the solvent receptacle.
4. **ALWAYS** remove spray tip when flushing the system. Operate the pump at the lowest possible pressure.

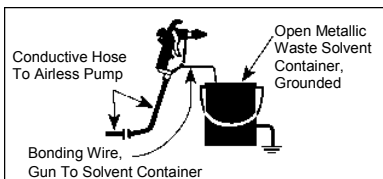

### GENERAL WARNINGS

1. **NEVER** leave a pressurized sprayer unattended.
2. Periodically inspect all hoses for leaks and/or abrasions and tighten all connections before use. **DO NOT ATTEMPT TO REPAIR** a defective hose. **REPLACE** it with another conductive hose.
3. **ALWAYS** relieve pressure in the system by turning bypass valve to **BYPASS** or triggering spray gun before disassembly of any component parts.

**CAUTION**

**Never store de-ionized, distilled, reverse osmosis or any pure grade of water in the pump. These fluids may cause corrosion**

**NOTE**

**BINKS is not responsible for misapplication of pumps. Consult your BINKS representative for application assistance.**

**NOTE**

**Be sure that all fluids, solvents and fillers to be used are chemically and physically compatible with wetted parts in the pump. Consult your BINKS representative for pump materials of constructions and compatibility information. Consult the fluid manufacture for information regarding the fluids to be used.**

**REPLACEMENT PARTS**  
The pump is designed to use authorized parts only. When using this pump with parts that do not comply with the minimum specifications and safety devices of Binks, the user assumes all risks and liabilities.

**⚠ WARNING**

**EXCESSIVE AIR PRESSURE**  
**Can cause personal injury, pump damage or property damage. Do not exceed maximum inlet air pressure as stated on motor model plate.**

HAZARD	CAUSE	SAFEGUARDS
<p>EXPLOSION</p> 	<p>STATIC ELECTRICITY</p> <p>Use of this equipment in a potentially explosive atmosphere.</p> <p>Vapors from flammable liquids can catch fire or explode from static electricity discharges.</p>	<ol style="list-style-type: none"> <li>1. If installing this equipment in a potentially explosive atmosphere, check the ATEX equipment category and temperature ratings meet the requirements for the zoned area.</li> <li>2. Check electrical continuity of the air supply to earth—should be no greater than <math>10^6 \Omega</math>.</li> <li>3. Electrically bond all metallic equipment to earth. Should be no greater than <math>1 \Omega</math>.</li> </ol>
<p><b>SPECIAL CONDITIONS FOR SAFE USE REQUIRED BY ATEX CERTIFICATION</b></p>	<p>Over pressurization of equipment can cause equipment failure or injury.</p> <p>Use lubricating medium resistant to carburisation.</p> <p>Improper operation or maintenance may create a hazard.</p>	<ol style="list-style-type: none"> <li>1. Do not exceed the stated maximum working pressures and motor speed as specified in this manual.</li> <li>2. Only a suitably approved static dissipating or conductive air supply hoses shall be attached to the equipment and terminated to the air supply.</li> <li>3. Air supplies (compressors, etc.) shall be sited in a nonhazardous area with a filter on the air intake system to prevent the ingress of dust or similar foreign material into the parts where compression takes place.</li> <li>4. Use lubricating medium resistant to carburisation and has an auto ignition temperature of more than <math>185^\circ\text{C}</math> for T4 equipment.</li> <li>5. User shall ensure all metallic parts of the equipment are suitably bonded to earth. Should be no greater than <math>1 \Omega</math>.</li> </ol>

**EC Declaration of Conformity**



We: ITW Oberflächentechnik GmbH, Justus-von-Liebig-Str. 31, 63128 Dietzenbach, Germany

As the manufacturer of the items listed below:

**Piston Pumps MX4-12 MX4-32**

Declare, under our sole responsibility, that, the equipment to which this document relates is in conformity with the following standards or other normative documents:

EN 13463-1:2009, EN 13463-5:2005, EN 982:1996 + A1:2008, EN 983:1996 + A1:2008 and EN 12621:2006

And thereby conform to the protection requirements of Council Directive 98/37/EC relating to **Machinery Safety Directive** and council Directive 94/9/EC relating to **Equipment and Protective Systems intended for use in Potentially Explosive Atmospheres;**

**CE Ex 2 II Gc T4**

Issued on: 1st July 2009

Authorized by:

ITW Oberflächentechnik GmbH  
 Justus-von-Liebig-Str. 31  
 D-63128 Dietzenbach  
 Telefon: +49 60 741 4 03-1



General Manager  
 Technical file lodged with;  
 TRL Compliance Ltd (Notified Body 0891)  
 Moss View  
 Nipe Lane  
 Up Holland  
 WN8 9PY, UK

## MX4-32 BARE PUMP ASSEMBLIES

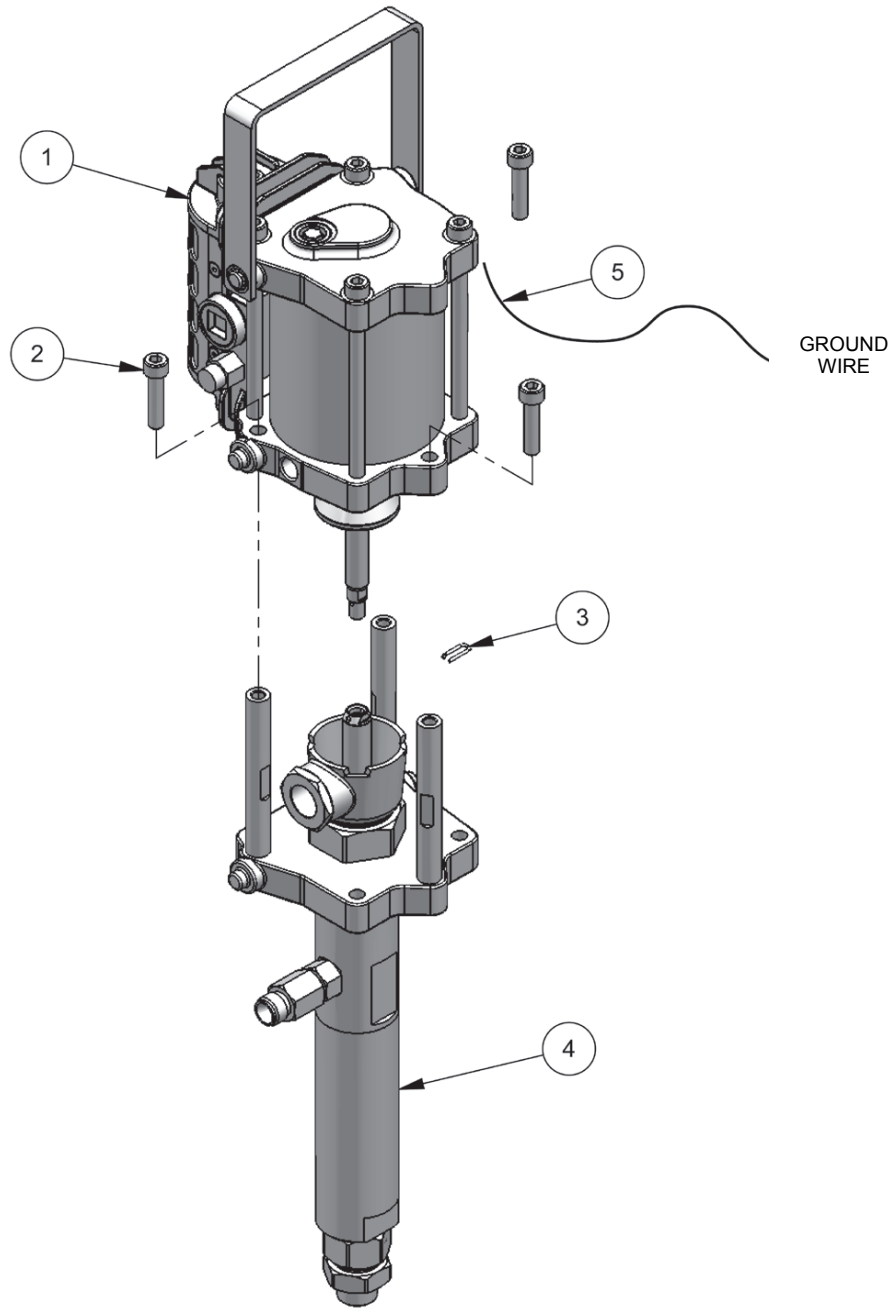

ITEM NO.	PART NUMBER	DESCRIPTION	0115-010000 QTY.	0115-01000-P QTY.	0115-010234 QTY.
1	0115-010002	AX85 AIR MOTOR ASSEMBLY	1	1	1
2	0115-010001	SOCKET HEAD CAP SCREW	3	3	3
3	0115-010099 •	ROD CLIP	1	1	1
4	0115-010045	FX4 FLUID SECTION ASSEMBLY, U-CUPS	-	-	1
4	0115-010052	FX4 FLUID SECTION ASSEMBLY, LEATHER/PTFE	1	-	-
4	0115-010052-P	FX4 FLUID SECTION ASSEMBLY, PTFE	-	1	-
5	0114-016243	GROUND WIRE KIT	1	1	1

• Part not sold separately. Available in repair kits: 0115-010220, 0115-010222 & 0115-010224.

## MX4-32 BARE PUMP ASSEMBLIES – MAINTENANCE

MAINTENANCE SYMBOLS	
#	ITEM NUMBER
#	DISASSEMBLY ORDER <i>(Reverse order for assembly)</i>
PG	PETROLEUM JELLY/GREASE
TS	THREAD SEALANT <i>(PTFE tape)</i>

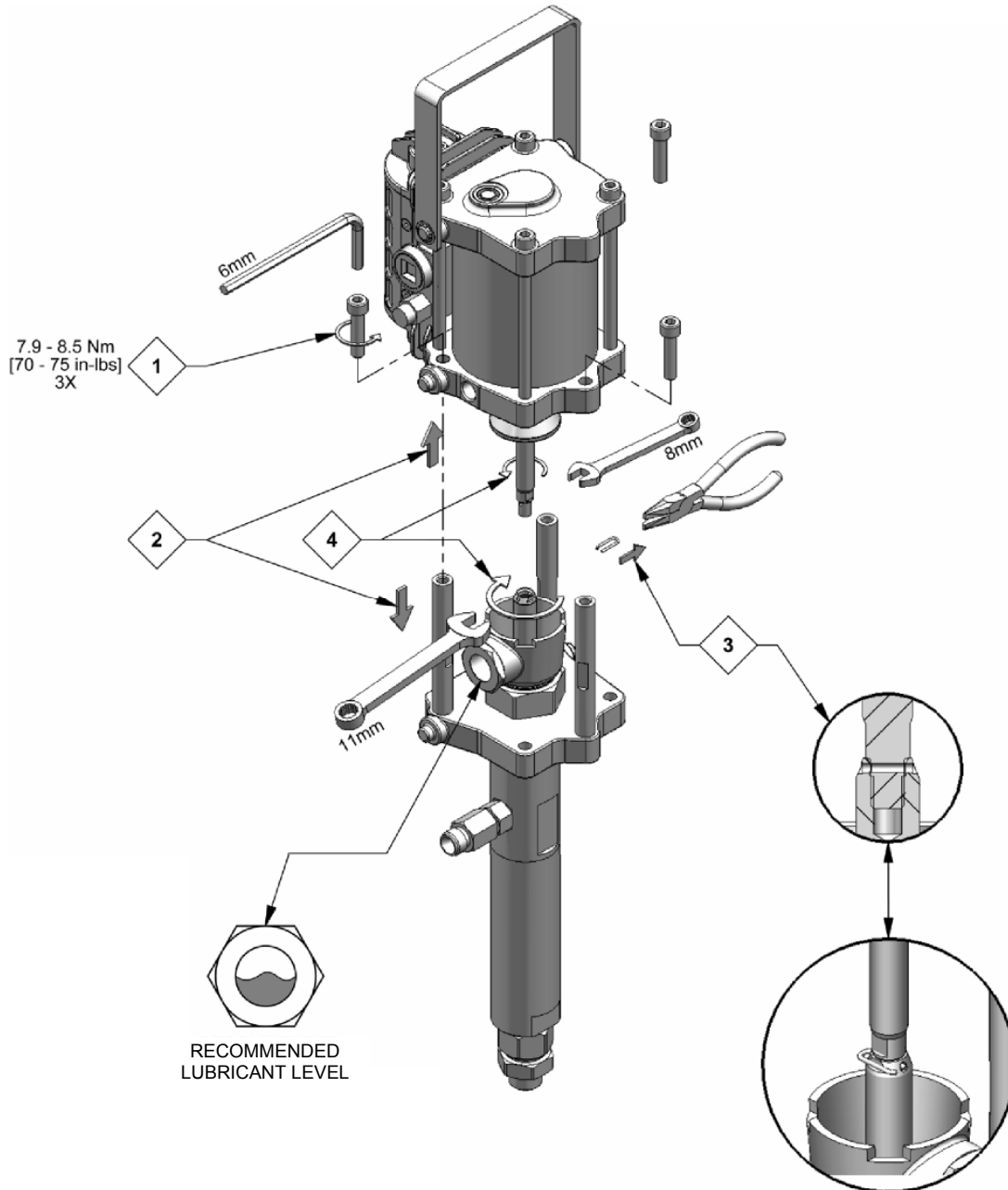

## MX4-32 BARE PUMP ASSEMBLIES – TROUBLESHOOTING

PROBLEM	CAUSE	SOLUTION
<b>Pump will not start</b>	No compressed air. Spray tip is blocked.	Check compressed air supply. Clean or replace the spray tip.
<b>Erratic operation of air motor, air motor stops</b>	Worn poppet assemblies. Worn or dirty spool and sleeve assembly.	Replace the poppet assemblies. Clean or replace the spool and sleeve assembly, as necessary.
<b>Continuous air leak from the exhaust</b>	Worn poppet assemblies. Worn piston seal. Worn diaphragm.	Replace poppet assemblies. Replace piston seal. Replace diaphragm.
<b>Material in solvent cup</b>	Worn or dirty upper packings.	Replace or clean upper packings as necessary.
<b>Pump does not stop on the down stroke</b>	Worn or dirty lower ball check.	Replace or clean the parts as necessary.
<b>Pump does not stop on the up stroke</b>	Worn or dirty upper ball check. Worn or dirty lower packings.	Replace or clean the parts as necessary.
<b>Pump runs erratically</b>	Blocked siphon kit. Blocked inlet filter or strainer. Low material level.	Replace or clean the siphon kit. Replace or clean the inlet filter or strainer. Replace or refill material container.
<b>Pump runs, with no output</b>	Loose connection in between pump and siphon kit. Stuck lower ball.	Check that all connections are tight. Replace or clean the parts as necessary.

# AX85 Air Motor Assembly

Model: 0115-010002

*Patent Pending*

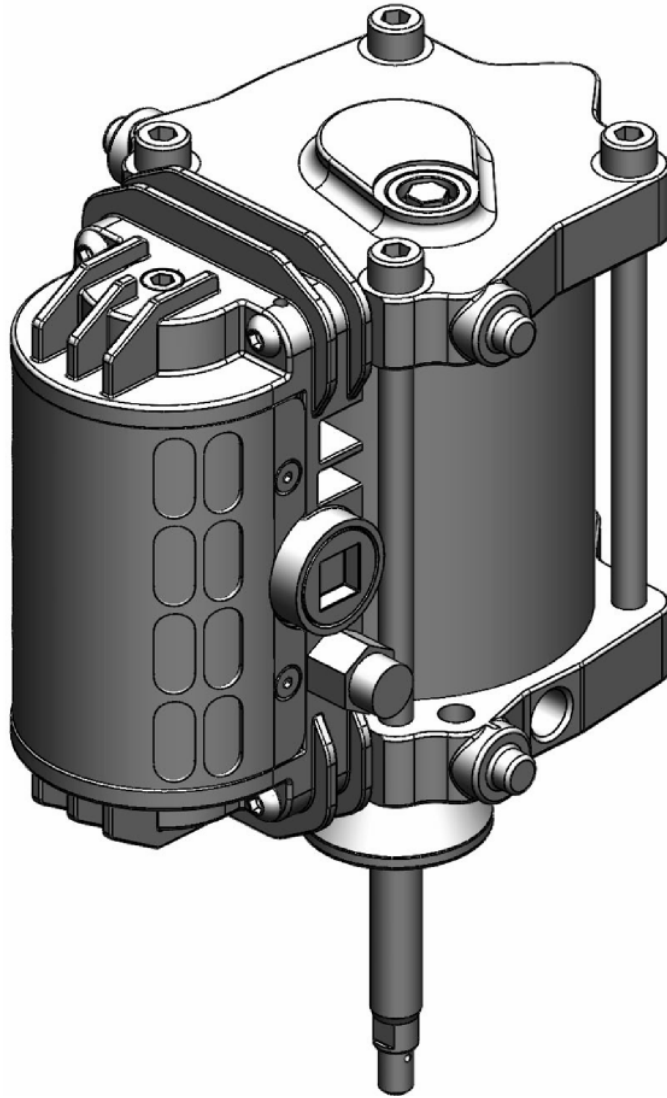

<b>SPECIFICATIONS</b>	
Maximum air inlet pressure:	8 bar [116 psi]
Maximum recommended continuous cycle rate:	20 cycles/min
Air inlet connection:	3/8" BSP(f)
Piston Diameter:	85 mm [3.3 in]
Stroke Length:	75 mm [3.0 in]



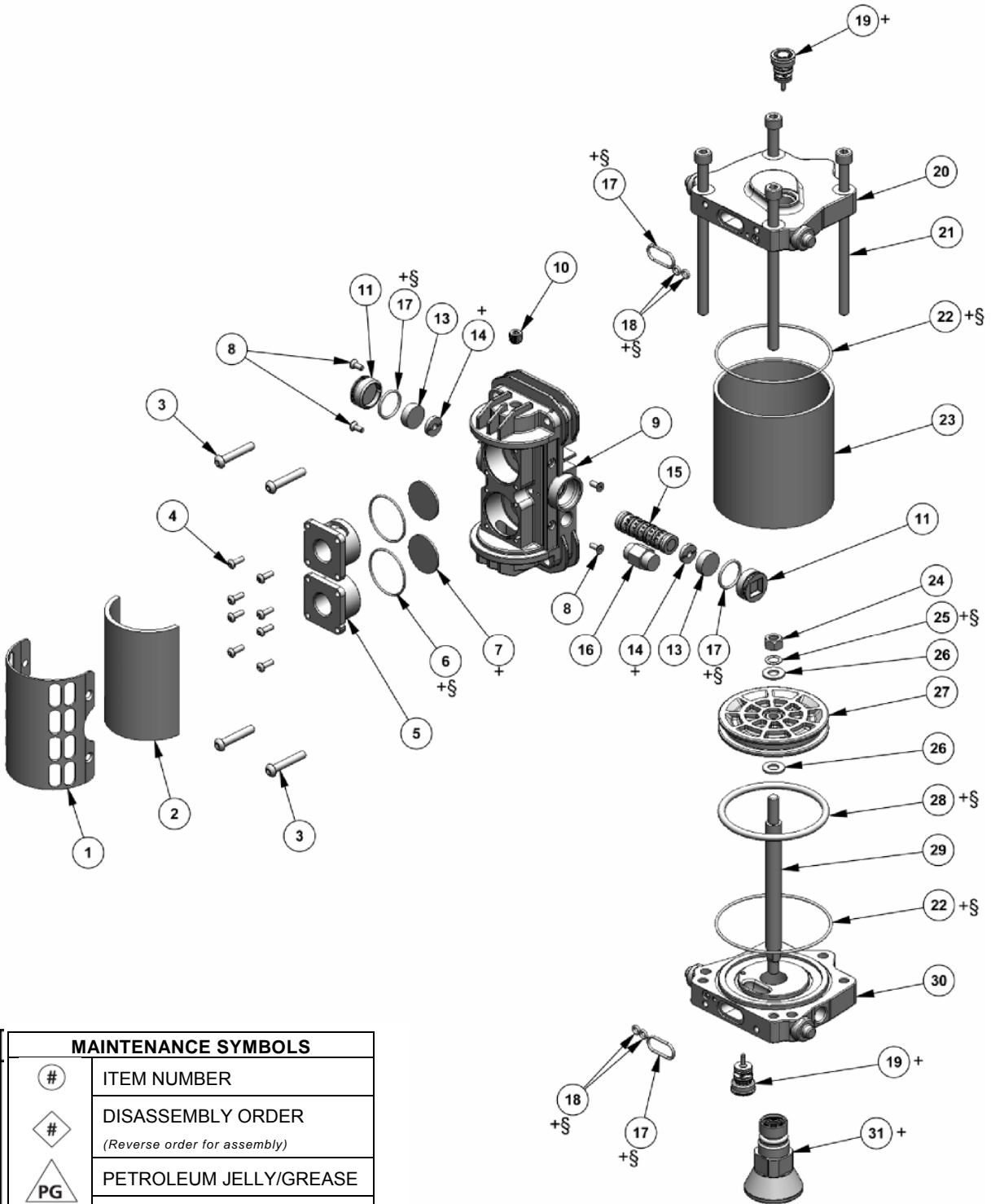

MAINTENANCE SYMBOLS	
#	ITEM NUMBER
#	DISASSEMBLY ORDER <i>(Reverse order for assembly)</i>
PG	PETROLEUM JELLY/GREASE
TS	THREAD SEALANT <i>(PTFE tape)</i>

+ Parts are included in 0115-01 0215 AX85 Repair Kit.  
 § Parts are included in 0115-010217 AX85 Seal Kit.

## AX85 AIR MOTOR ASSEMBLY

ITEM NO.	PART NUMBER	DESCRIPTION	0115-01 0088 QTY.
1	0115-010023	EXHAUST COVER SCREEN	1
2	0115-010022	EXHAUST COVER	1
3	0115-010026	BUTTON HEAD CAP SCREW	4
4	0115-010073	BUTTON HEAD CAP SCREW	8
5	0115-010019	QUICK EXHAUST VALVE CAGE	2
6	0115-010021 +§	O-RING	2
7	0115-010020 +	DIAPHRAGM	2
8	0115-010024	FLAT HEAD COUNTER SUNK CAP SCREW	4
9	0115-010097	VALVE BLOCK ASSEMBLY	1
10	0115-010107	PIPE PLUG	1
11	0115-010018	VALVE BLOCK END CAP	2
13	0115-010017	MAGNET	2
14	0115-010016 +	BUMPER	2
15	0115-010015	SPOOL AND SLEEVE ASSEMBLY	1
16	0114-014774	SAFETY VALVE	1
17	0115-010049 +§	O-RING	4
18	0115-010051 +§	O-RING	4
19	0115-010037 +	POPPET ASSEMBLY	2
20	0115-010004	UPPER END CAP MACHINING	1
21	0115-010029	SOCKET HEAD CAP SCREW	4
22	0115-010050 +§	CYLINDER SEAL, 85mm	2
23	0115-010003	CYLINDER, 85mm	1
24	0115-010096	LOCKNUT	1
25	0115-010036 +§	SEALING RING	1
26	0115-010035	FLAT WASHER	2
27	0115-010032	PISTON, 85mm	1
28	0114-014466 +§	PISTON SEAL, 85mm	1
29	0115-010034	MOTOR ROD	1
30	0115-010006	LOWER END CAP MACHINING	1
31	0115-010008 +	MOTOR ROD CARTRIDGE ASSEMBLY (INCLUDES SEALS)	1

+ Parts are included in 0115-010215 AX85 Repair Kit.

§ Parts are included in 0115-010217 AX85 Seal Kit.

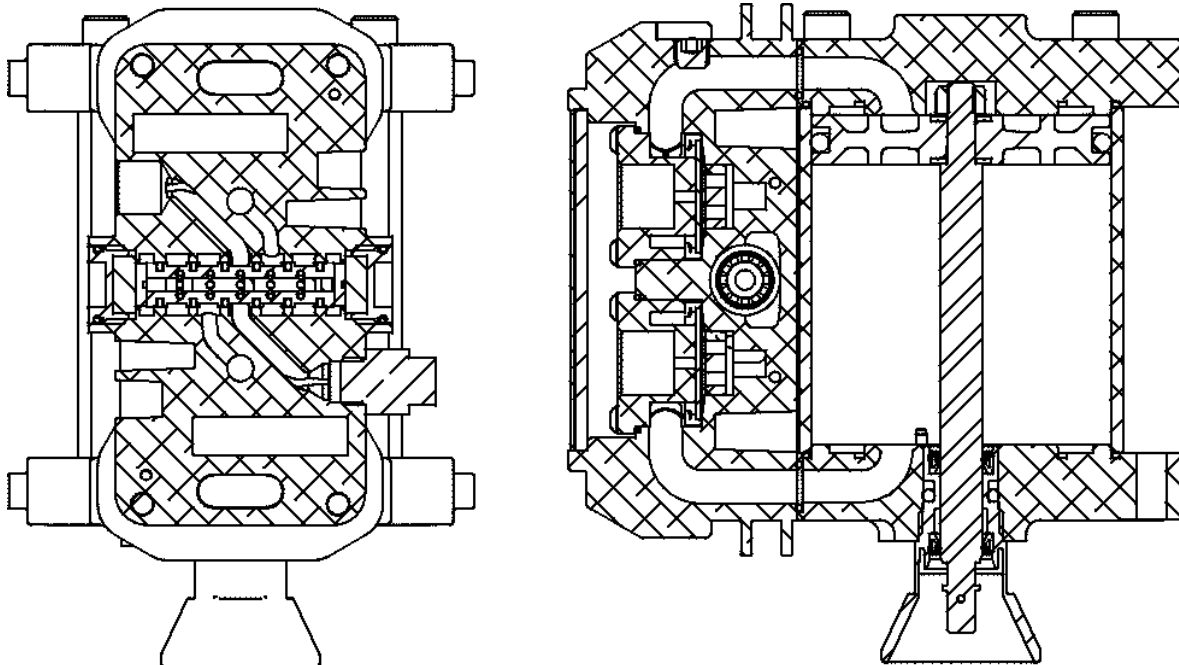

# AX85 AIR MOTOR ASSEMBLY – MAINTENANCE

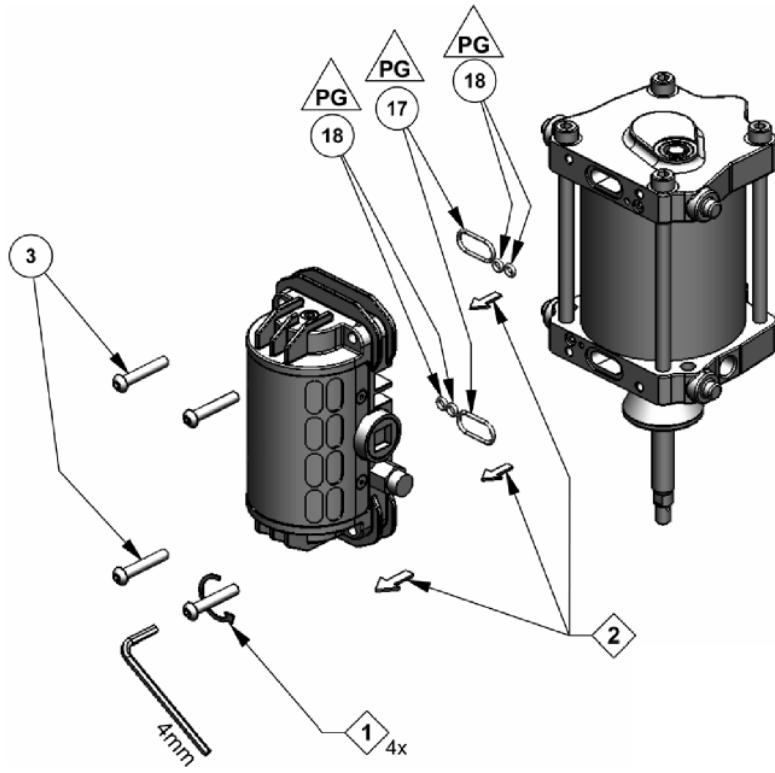

MAINTENANCE SYMBOLS	
#	ITEM NUMBER
#	DISASSEMBLY ORDER <i>(Reverse order for assembly)</i>
PG	PETROLEUM JELLY/GREASE
TS	THREAD SEALANT <i>(PTFE tape)</i>

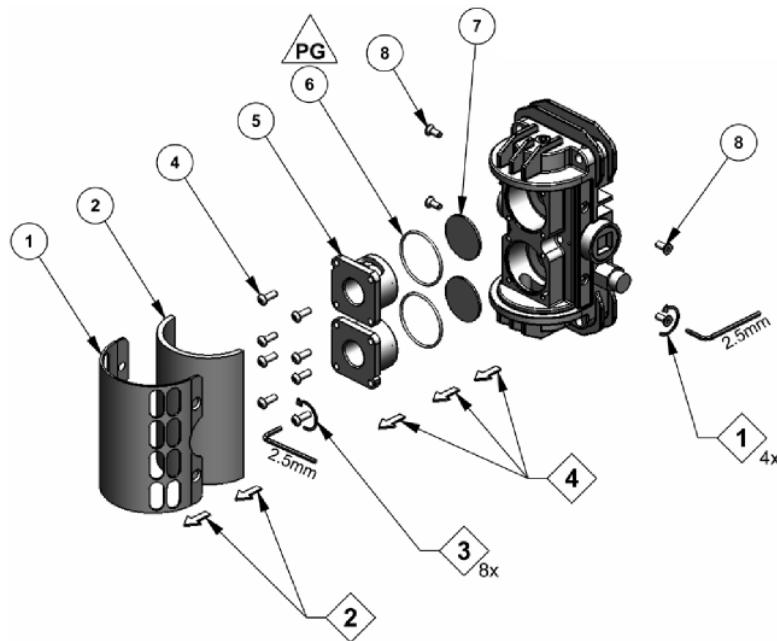

## AX85 AIR MOTOR ASSEMBLY – MAINTENANCE

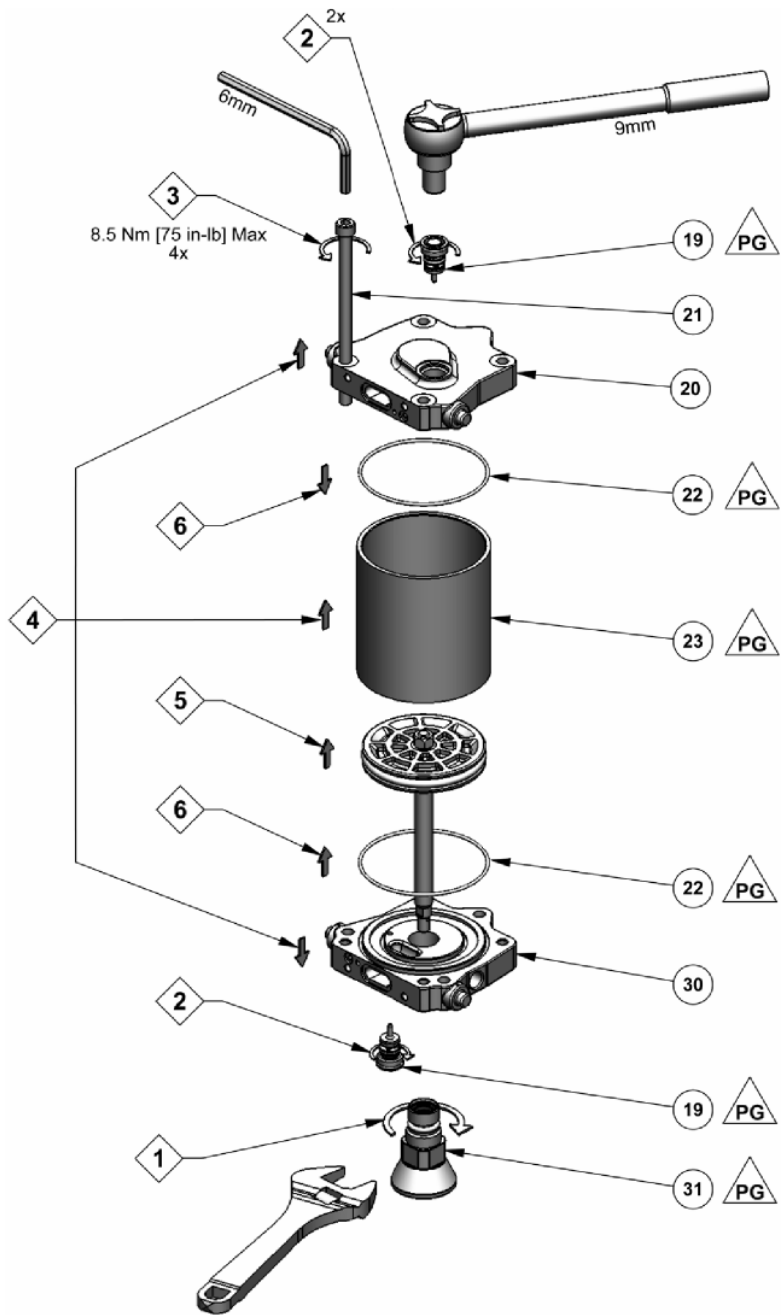

MAINTENANCE SYMBOLS	
#	ITEM NUMBER
#	DISASSEMBLY ORDER <i>(Reverse order for assembly)</i>
PG	PETROLEUM JELLY/GREASE
TS	THREAD SEALANT <i>(PTFE tape)</i>

## AX85 AIR MOTOR ASSEMBLY – MAINTENANCE

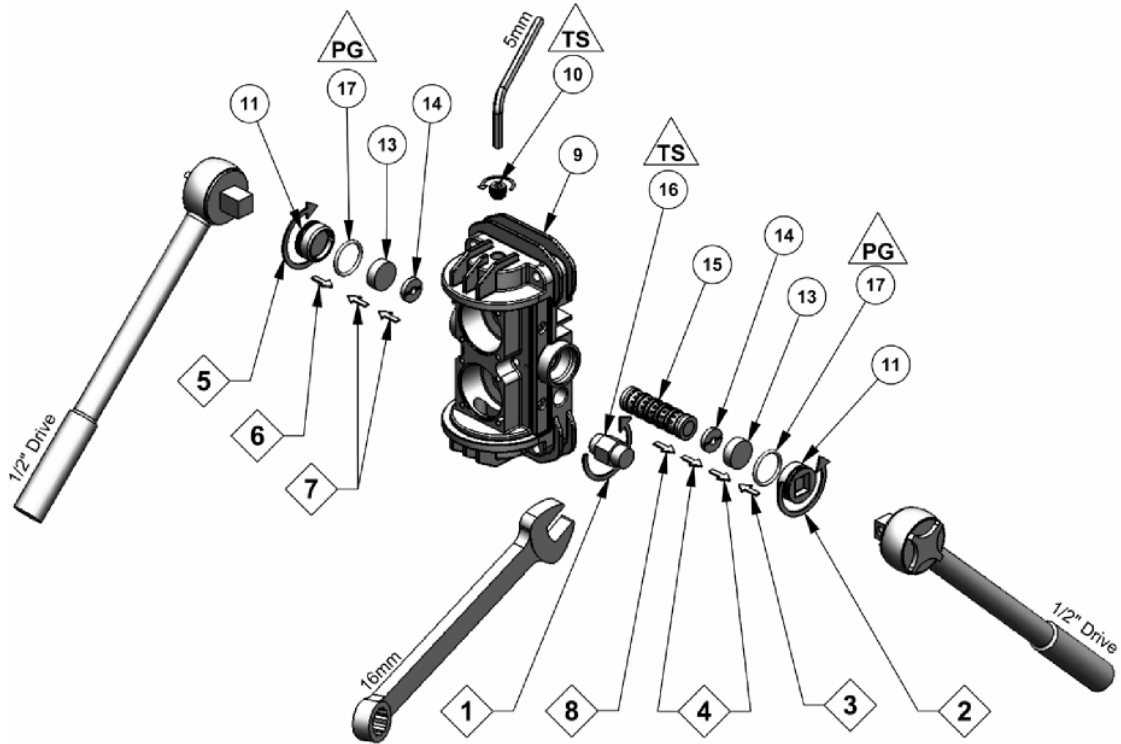

MAINTENANCE SYMBOLS	
#	ITEM NUMBER
#	DISASSEMBLY ORDER <i>(Reverse order for assembly)</i>
PG	PETROLEUM JELLY/GREASE
TS	THREAD SEALANT <i>(PTFE tape)</i>

12.4 - 13.6 Nm  
[110 - 120 in-lb]

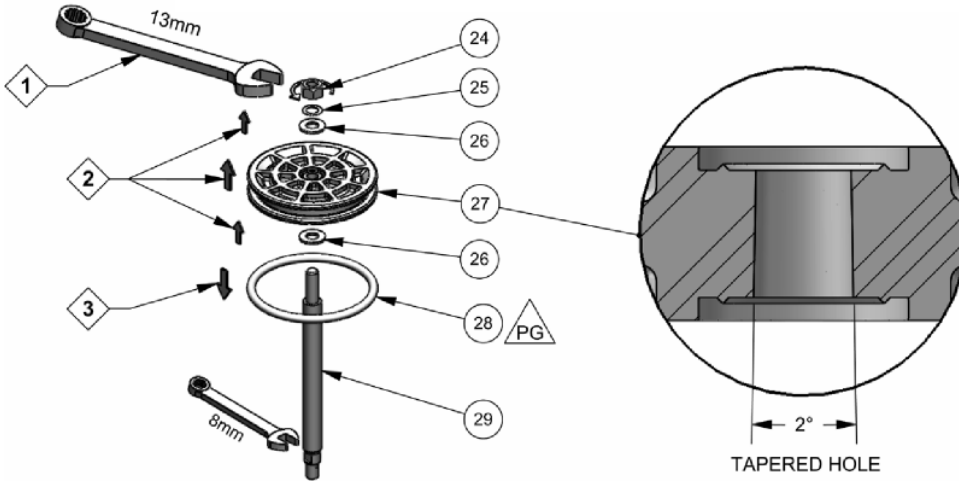

## AX85 AIR MOTOR ASSEMBLY – TROUBLESHOOTING

<b>PROBLEM</b>	<b>CAUSE</b>	<b>SOLUTION</b>
<b>Pump will not start</b>	No compressed air. System is blocked.	Check compressed air supply. Clear the blockage.
<b>Erratic operation of air motor, air motor stops</b>	Worn poppet assemblies. Worn or dirty spool and sleeve assembly.	Replace poppet assemblies. Clean or replace the spool and sleeve assembly as necessary.
<b>Continuous air leak from the exhaust</b>	Worn poppet assemblies. Worn piston seal. Worn diaphragm.	Replace poppet assemblies. Replace piston seal. Replace diaphragm.

# FX4 Fluid Pump Assemblies

Models: 0115-010052 (PTFE/Leather Chevrons), 0115-010052-P (PTFE Chevrons),  
0115-010045 (UHMW U-Cups)

Patent Pending

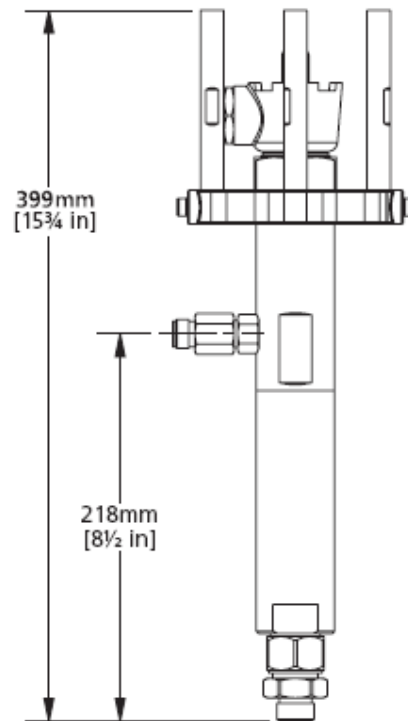
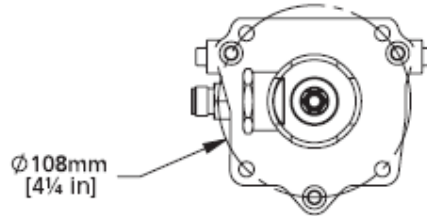
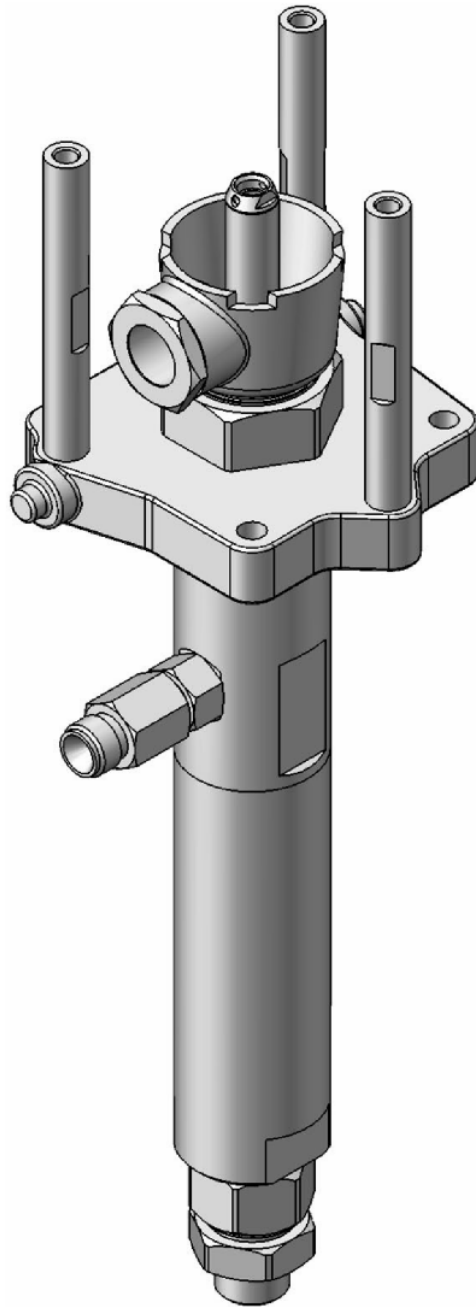

## SPECIFICATIONS

Maximum fluid pressure:	256 bar [3712 psi]
Displacement per cycle:	24 cc [0.8 oz]
Output @ 60 cycles/min:	1.4 L/m [0.4 gal/m]
Fluid inlet size:	1/2" NPS(m)
Fluid outlet size:	3/8" NPSM(m)
Weight:	3.7 kg [8.1 lbs]
Wetted parts materials of construction:	Stainless Steel, Tungsten Carbide, Hard Chrome, PTFE, Polyethylene, Leather

## FX4 FLUID PUMP ASSEMBLIES (CHEVRON PACKINGS)

Models: 0115-010052 (PTFE/Leather Chevrans), 0115-010052-P (PTFE Chevrans)

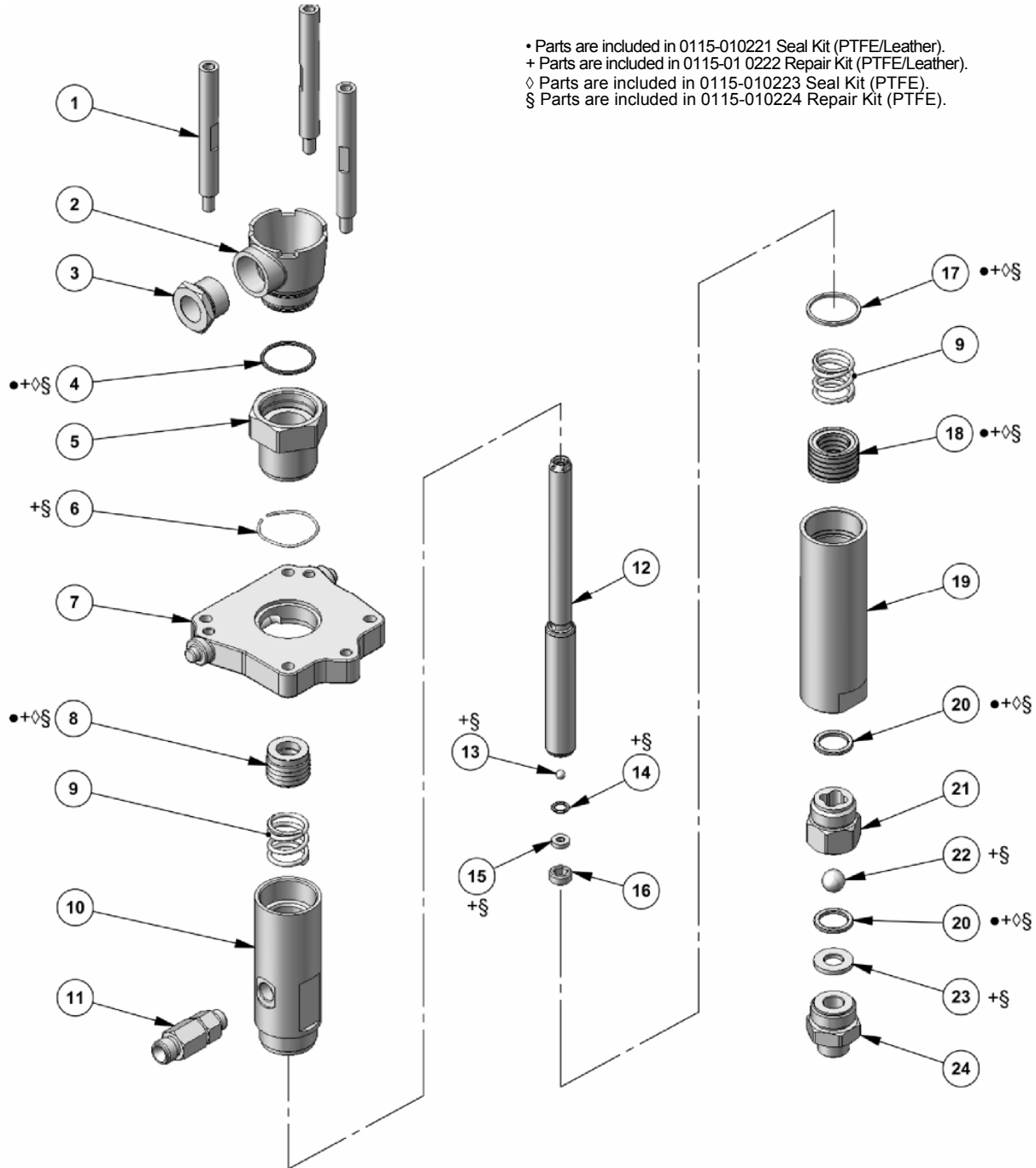

- Parts are included in 0115-010221 Seal Kit (PTFE/Leather).
- + Parts are included in 0115-01 0222 Repair Kit (PTFE/Leather).
- ⋄ Parts are included in 0115-010223 Seal Kit (PTFE).
- § Parts are included in 0115-010224 Repair Kit (PTFE).

MAINTENANCE SYMBOLS	
#	ITEM NUMBER
#	DISASSEMBLY ORDER <i>(Reverse order for assembly)</i>
PG	PETROLEUM JELLY/GREASE
TS	THREAD SEALANT <i>(PTFE tape)</i>

### 0115-010256 CHECK VALVE ASSEMBLY

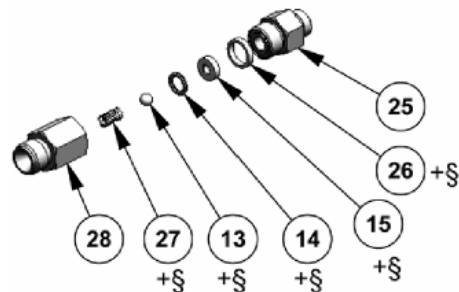



**FX4 FLUID PUMP ASSEMBLIES (CHEVRON PACKINGS)**  
**Models: 0115-010052 (PTFE/Leather Chevrons), 0115-010052-P (PTFE Chevrons)**

ITEM NO.	PART NUMBER	DESCRIPTION	0115-010052 Qty.	0115-010052-P Qty.
1	0115-010053	PUMP TIE ROD	3	3
2	0115-010059	SOLVENT CUP	1	1
3	0115-010060	SIGHT GAUGE	1	1
4	0115-010061 *+◇§	SOLVENT CUP SEAL	1	1
5	0115-01 0062	PACKING ADAPTER	1	1
6	0115-010058 +§	WAVE SPRING	1	1
7	0115-01 0204	ADAPTER PLATE MACHINING	1	1
8	0115-010171 **	UPPER PACKING SET (PTFE/LEATHER)	1	-
8	0115-010206 ◇§	UPPER PACKING SET (PTFE)	-	1
9	0115-01 0111	PACKING SPRING	2	2
10	0115-010055	UPPER PUMP TUBE	1	1
11	0115-010256	CHECK VALVE ASSEMBLY	1	1
12	0115-01 0063	PUMP ROD (HARD CHROME)	1	1
13	0114-014745 +§	UPPER BALL, 6mm	2	2
14	0115-010065 +§	ROD SEAT SEAL	2	2
15	0115-010066 +§	ROD SEAT	2	2
16	0115-010067	ROD SEAT NUT	1	1
17	0115-010064 *+◇§	LOWER PUMP TUBE SEAL	1	1
18	0115-010173 **	LOWER PACKING SET (PTFE/LEATHER)	1	-
18	0115-010207 ◇§	LOWER PACKING SET (PTFE)	-	1
19	0115-010056	LOWER PUMP TUBE	1	1
20	0115-010068 **+◇§	LOWER SEAT SEAL	2	2
21	0115-010057	LOWER BALL CAGE	1	1
22	0114-014237 +§	LOWER BALL, 15mm	1	1
23	0115-010069 +§	LOWER SEAT	1	1
24	0115-010070	SEAT RETAINER	1	1
25	0115-01 0258	FLUID OUTLET FITTING	1	1
26	0115-010259 +§	CHECK SEAL	1	1
27	0115-010087 +§	VALVE SPRING	1	1
28	0115-010257	CHECK VALVE HOUSING	1	1
29	0115-010099 +§	ROD CLIP (not shown)	1	1

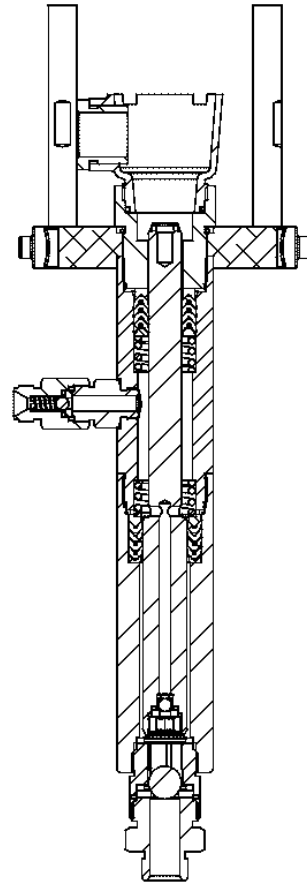

- Parts are included in 0115-010221 Seal Kit (PTFE/Leather).
- + Parts are included in 0115-010222 Repair Kit (PTFE/Leather).
- ◇ Parts are included in 0115-010223 Seal Kit (PTFE).
- § Parts are included in 0115-010224 Repair Kit (PTFE).

## FX4 FLUID PUMP ASSEMBLIES (U-CUPS) 0115-010045 (UHMW U-Cups)

- Parts are included in 0115-010219 Seal Kit (U-CUPS).
- + Parts are included in 0115-010220 Repair Kit (U-CUPS).

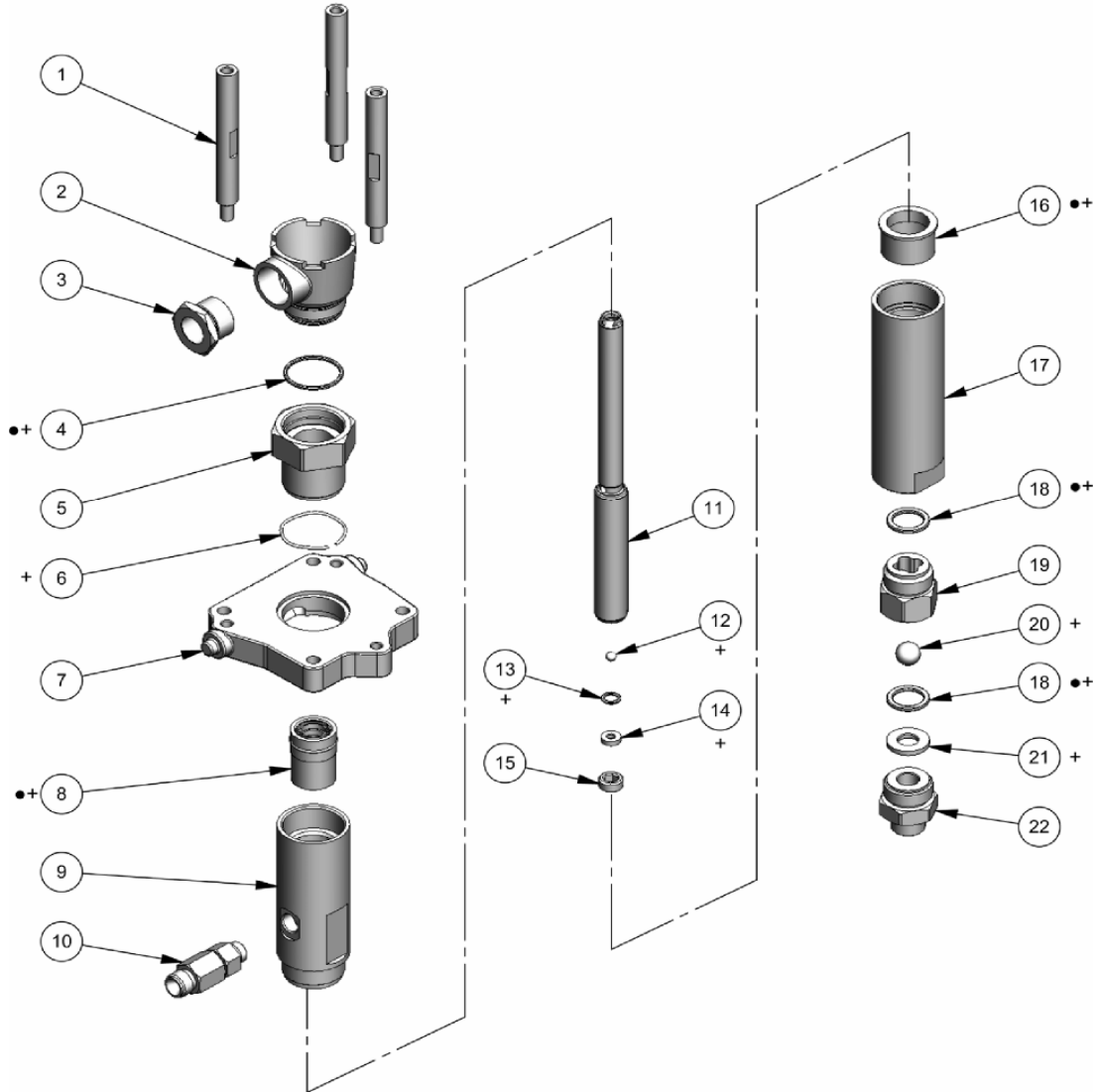

### 0115-010256 CHECK VALVE ASSEMBLY

MAINTENANCE SYMBOLS	
#	ITEM NUMBER
#	DISASSEMBLY ORDER <i>(Reverse order for assembly)</i>
PG	PETROLEUM JELLY/GREASE
TS	THREAD SEALANT <i>(PTFE tape)</i>

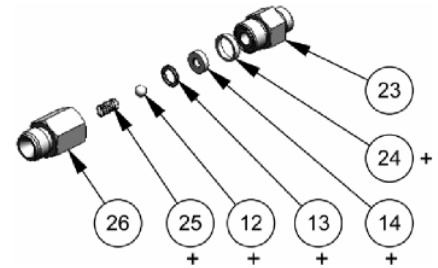

## FX4 FLUID PUMP ASSEMBLIES (U-CUPS) 0115-010045 (UHMW U-Cups)

ITEM NO.	PART NUMBER	DESCRIPTION	0115-010045 QTY.
1	0115-010053	PUMP TIE ROD	3
2	0115-010059	SOLVENT CUP	1
3	0115-010060	SIGHT GAUGE	1
4	0115-010061 •+	SOLVENT CUP SEAL	1
5	0115-01 0062	PACKING ADAPTER	1
6	0115-010058 +	WAVE SPRING	1
7	0115-01 0204	ADAPTER PLATE MACHINING	1
8	0115-010166 •+	UPPER SEAL CARTRIDGE ASSEMBLY	1
9	0115-010055	UPPER PUMP TUBE	1
10	0115-010256	CHECK VALVE ASSEMBLY	1
11	0115-01 0063	PUMP ROD (HARD CHROME)	1
12	0114-014745 +	UPPER BALL, 6mm	2
13	0115-010065 +	ROD SEAT SEAL	2
14	0115-010066 +	ROD SEAT	2
15	0115-010067	ROD SEAT NUT	1
16	0115-010169 •+	LOWER SEAL CARTRIDGE ASSEMBLY	1
17	0115-010056	LOWER PUMP TUBE	1
18	0115-010068 •+	LOWER SEAT SEAL	2
19	0115-010057	LOWER BALL CAGE	1
20	0114-014237 +	LOWER BALL, 15mm	1
21	0115-010069 +	LOWER SEAT	1
22	0115-010070	SEAT RETAINER	1
23	0115-01 0258	FLUID OUTLET FITTING	1
24	0115-010259 +	CHECK SEAL	1
25	0115-010087 +	VALVE SPRING	1
26	0115-010257	CHECK VALVE HOUSING	1
27	0115-010099 +	ROD CLIP (not shown)	1

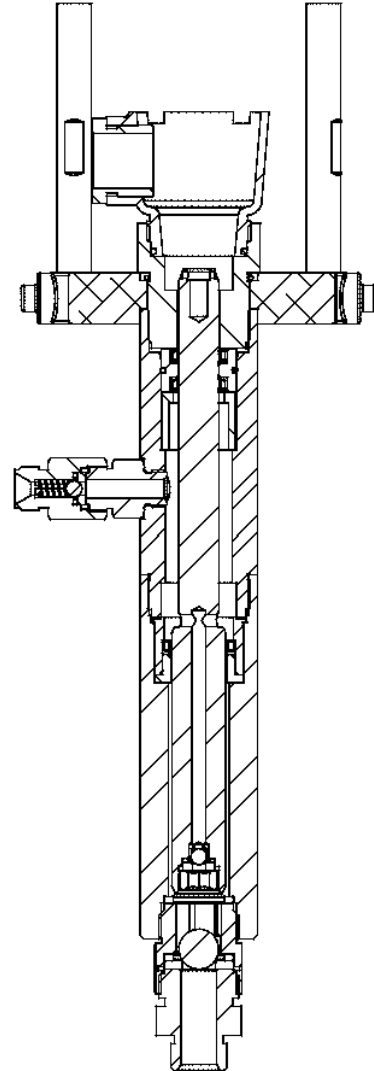

• Parts are included in 0115-010219 Seal Kit (U-CUPS).  
+ Parts are included in 0115-010220 Repair Kit (U-CUPS).

## FX4 FLUID PUMP (CHEVRONS) – MAINTENANCE

Models: 0115-010052 (PTFE/Leather Chevrans), 0115-010052-P (PTFE Chevrans)

MAINTENANCE SYMBOLS	
#	ITEM NUMBER
#	DISASSEMBLY ORDER <i>(Reverse order for assembly)</i>
PG	PETROLEUM JELLY/GREASE
TS	THREAD SEALANT <i>(PTFE tape)</i>

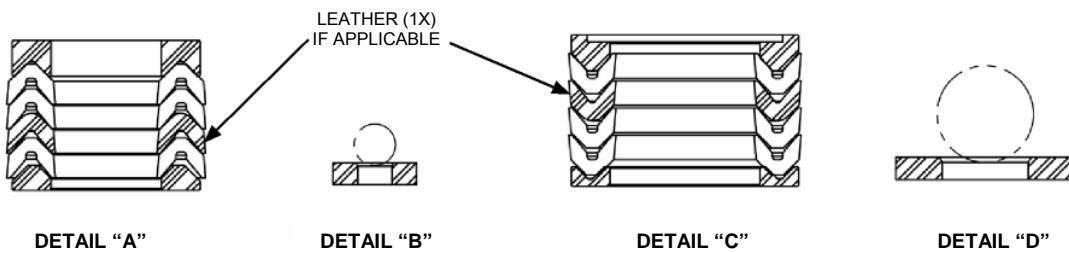
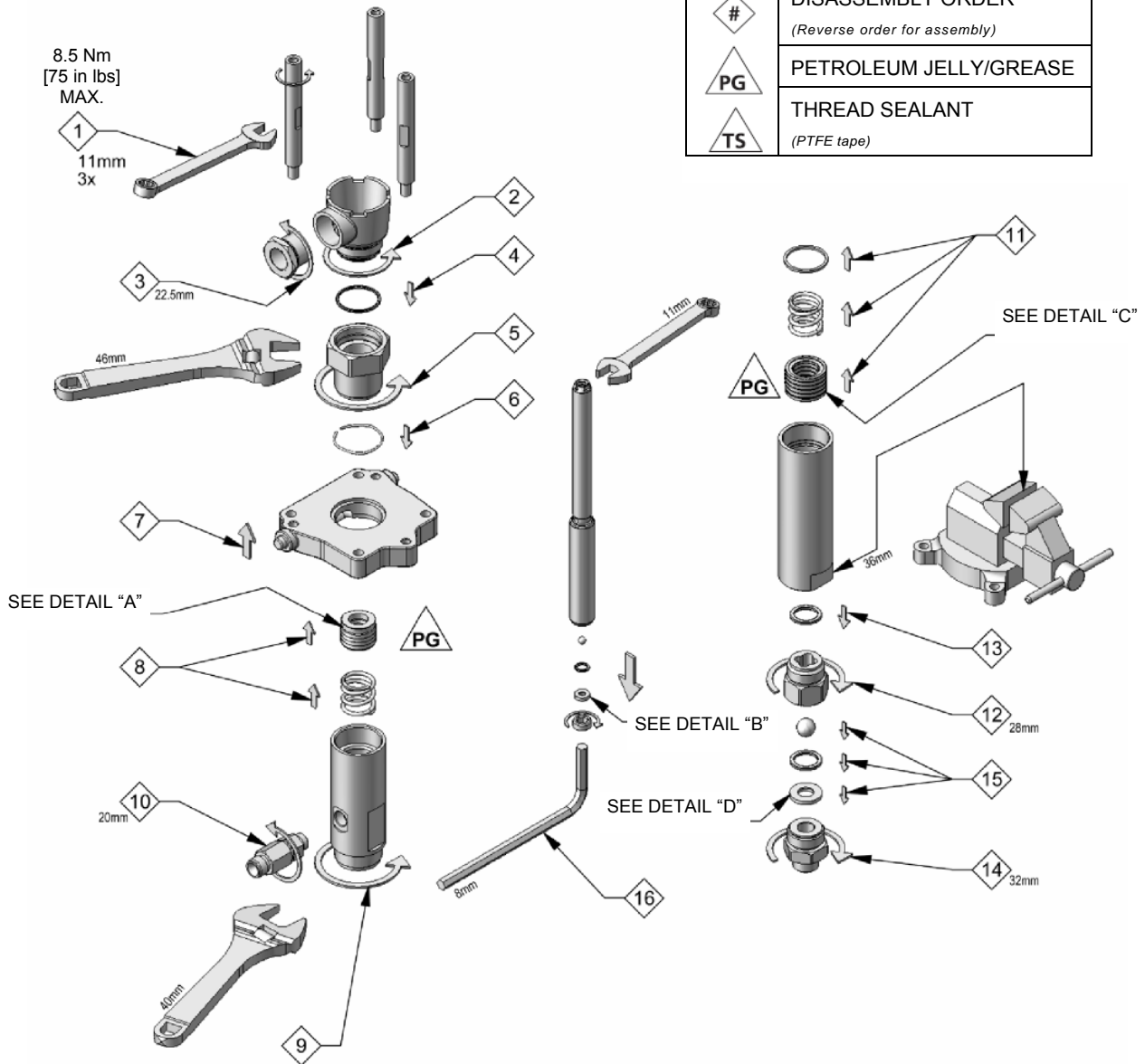

## FX4 FLUID PUMP (U-CUPS) – MAINTENANCE

### 0115-010045 (UHMW U-Cups)

MAINTENANCE SYMBOLS	
#	ITEM NUMBER
#	DISASSEMBLY ORDER <i>(Reverse order for assembly)</i>
PG	PETROLEUM JELLY/GREASE
TS	THREAD SEALANT <i>(PTFE tape)</i>

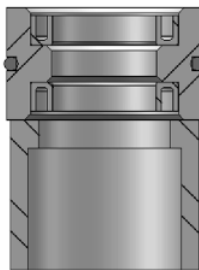
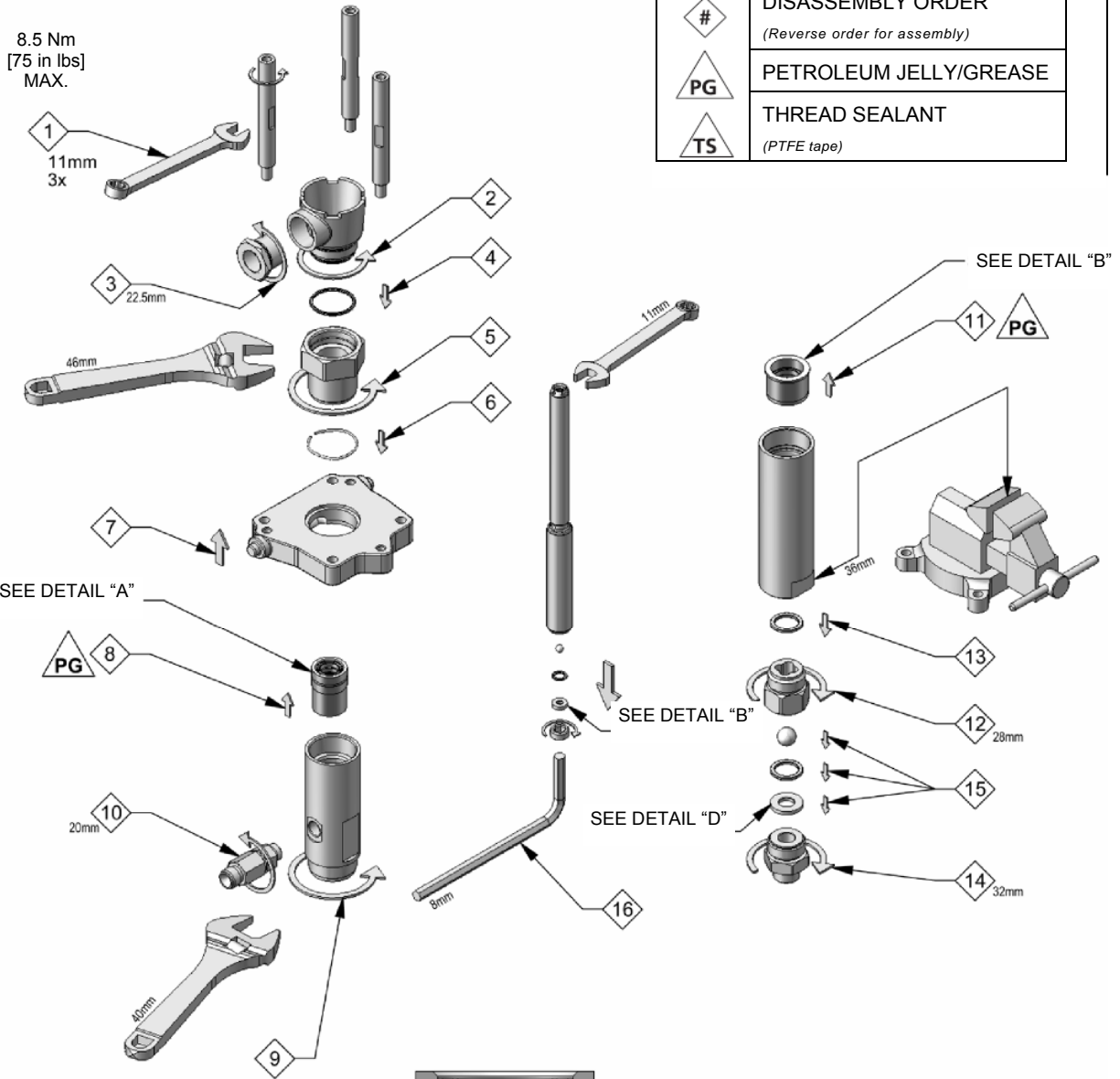

DETAIL "A"

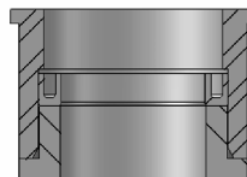

DETAIL "B"

## FX4 FLUID PUMP ASSEMBLIES – TROUBLESHOOTING

PROBLEM	CAUSE	SOLUTION
<b>Material in solvent cup</b>	Worn or dirty upper packings.	Replace or clean upper packings as necessary.
<b>Pump does not stop on the down stroke</b>	Worn or dirty lower ball check.	Replace or clean the parts as necessary.
<b>Pump does not stop on the up stroke</b>	Worn or dirty upper ball check. Worn or dirty lower packings.	Replace or clean the parts as necessary.
<b>Pump runs erratically</b>	Blocked material siphon kit. Blocked inlet filter or strainer. Low material level.	Replace or clean the siphon kit. Replace or clean inlet filter or strainer. Replace or refill material container.
<b>Pump runs, with no output</b>	Loose connection in between pump and siphon assembly. Stuck lower ball.	Check that all connections are tight. Replace or clean the parts as necessary.

## ACCESSORIES FOR YOUR MX4-32 BARE PUMP

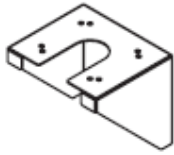

BRACKET  
0115-010179



TROLLEY ASSEMBLY  
0115-010186  
Service Bulletin 77-2915



TRIPOD ASSEMBLY  
0115-010100  
Service Bulletin 77-2915



SUCTION HOSE ASSEMBLY  
0115-010236 (20 MESH)  
Service Bulletin 77-2915



AIR CONTROLS  
0115-010180 (Air Assist)  
0115-010198 (Airless)  
Service Bulletin 77-2915



FLUID FILTER (100 MESH)  
0110-009130  
Service Bulletin 77-2915



LUBRICATING OIL FOR  
FX-4 FLUID PUMP  
0114-009433 (Solvent Based Materials)  
0114-014871 (Water Based Materials)

---

## WARRANTY

This product is covered by Binks' 5 Year Limited Warranty.

---

**Binks European Sales and Service Listing: [www.itwifeuro.com](http://www.itwifeuro.com)**

---

### ITW Industrial Finishing

Binks has authorized distributors throughout the world. For technical assistance or the distributor nearest you, see listing below.

#### U.S./Canada Technical Service Office:

195 Internationale Blvd.  
Glendale Heights, IL 60139  
Toll-Free Telephone: 1-888-992-4657 (U.S.A. and Canada only)  
Toll-Free Fax: 1-888-246-5732

#### ITW Industrial Finishing:

Ringwood Road, Bournemouth  
BH11 9LH England  
Tel: +44(0) 1202 571111 Fax: +44(0) 1202 573488  
Email: [industrial.mktg@itwfinishing.co.uk](mailto:industrial.mktg@itwfinishing.co.uk)

#### ITW Surfaces et Finitions:

163-171 Av des Auréals  
26014 Valence cedex France  
Tel: +33 4 75 75 27 00 Fax: +33 4 75 75 27 59  
Email: [mkt@itwsf.com](mailto:mkt@itwsf.com)

#### ITW Oberflächentechnik GmbH:

Justus-von-Liebig-Straße 31  
D-63128 Dietzenbach Germany  
Tel: +49 (0) 6074-403-1 Fax: +49 (0) 6074-403-300  
Email: [marketing@itw-finishing.de](mailto:marketing@itw-finishing.de)



[www.itwifeuro.com](http://www.itwifeuro.com)

7/09 ©2009 ITW Industrial Finishing All rights reserved. Printed in U.S.A.