

DAGR™ by DEVILBISS®

Service Bulletin

SB-2-055-B

Replaces SB-2-055-A

AIRBRUSH INSTRUCTIONS AND MAINTENANCE

Thank you for purchasing your DeVilbiss DAGR™ airbrush! You will find that this high quality, versatile airbrush gives the demanding professional artist the full range of performance—from spraying fine lines to wide backgrounds—with a wide range of materials—from solvent-based automotive paints to waterbase inks.

DAGR airbrushes are precision made with micro machining and high quality materials. Each airbrush is spray tested before being packaged in its collector's tin, assuring that it meets the tough quality standards you have come to expect from DeVilbiss. With proper care, your DAGR airbrush will provide you with excellent performance to express your creativity.

SPECIFICATIONS

Operating Pressures:
20 to 50 psi

Maximum Inlet Pressure:
175 psi

Airbrush Plating:
Nickel, copper, chrome

Needle Packing:
Teflon® (solvent-proof)

GET READY TO SPRAY

SAFETY FIRST

Please read all safety information on pages 8 and 9.

Connect to Compressed Air

Connect your DAGR airbrush to a regulated air line or select an appropriate compressor. The DeVilbiss Airblade™ single piston compressor is a compact, economical choice for the beginner and will provide approximately 25-30 psi of air pressure to the DAGR airbrush. The two-piston DeVilbiss Airblade Deuce™ can provide up to 50 psi to the DAGR airbrush and will give you complete versatility. At 35-40 psi, the DAGR will produce a high paint flow for shadow, fade, and background spray, as well as for detail work and fine lines.

Assemble Airbrush to Compressor

Connect the air hose to the compressor and airbrush, then turn on the compressor. If using an Airblade™ compressor, adjust the pressure to between 20 and 30 psi. Listen for any air leaks in the compressor or air hose fittings. Point the airbrush away from you and press down on the trigger (#14) to start the flow of air through the airbrush. Place a small amount of solvent or cleaner into the cup and pull back on the trigger. This will clean out any residual factory testing material that may still be in the airbrush.

Mix Paint and Fill the Removable Cup

Follow the paint manufacturer's instructions and thin the paint with its proper solvent. Filter it through a nylon mesh strainer. It is best to "over-reduce" or prepare the paint relatively thin and make continuous passes across your work to achieve the desired shade. This will also decrease paint buildup on the needle and cleaning time. The DAGR features a removable cup. Depending on the amount of paint you wish to spray, use the standard 1/3 oz. (9 cc) cup or select an optional 1/4 oz. (7 cc) or 1/2 oz. (14 cc) cup. For small amounts of material,

simply remove the cup and fill the cup socket, which will give you best visibility for close-up work.

GENERAL OPERATION

The DAGR is a double action airbrush for fine control. Push the trigger down for air flow and pull the trigger back for paint flow. For best results during spraying, keep air flow even when you have stopped paint flow.

Air Pressure Range

Working pressures vary between 20 and 50 psi, depending on what type of work is being done, what spray characteristics are desired, and paint viscosity. Generally, thicker paints or higher paint flow will require higher pressures.

Spraying Fine Lines and Detail

To spray a fine line or detail, press the trigger down for air flow and pull it back slightly for paint flow while moving the airbrush very close to the surface. Control the thickness of the line by adjusting the distance between the airbrush and the surface and by adjusting the amount of paint flow with the trigger. An even

finer line can be achieved by carefully removing the crown cap (#1) and moving the airbrush closer to the surface.

NOTE: The needle and nozzle are very finely machined. A slight bend on the tip of the needle can result in an uneven pattern. The crown cap protects the needle yet still allows fine lines to be sprayed.

Wide Lines, Fades, and Background Spraying

For wider lines, fades, and background spraying, pull the trigger further back for more paint flow. Increase the distance between the airbrush and artwork up to six inches to control the line width. Increasing the air pressure will also affect the spray width. The DAGR will spray a background width of approximately two inches. Speed of movement controls the density of the color and fading effects.

Spraying Lines Without Heavy Ends

To spray a fine or wide line without heavy ends, start moving the airbrush with the trigger pushed down for air. Then pull the trigger back for paint flow at the beginning of the line and stop paint flow at the end, but continue the motion of the airbrush.

Stippling (Dots)

Stippling (coarse or fine dots) can add special textured effects to artwork. Simply remove the crown cap (#1) and air cap (#2) and adjust the air pressure between 5 and 50 psi. Lower air pressure will produce coarse dots; higher pressure will produce fine dots. Paint viscosity affects stippling, as well.

Removing Clogs

The cutaway handle (#21) allows the artist to remove paint buildup from the tip of the airbrush without removing the handle and needle. Just grip the exposed needle locknut (#25) and pull back while pushing down on the trigger (#15). More paint will flow past the needle and tip, clearing the clog.

Another method is to keep a second airbrush nearby that has solvent in the cup and use it to spray the nozzle/needle tip.

A third method is to increase the air pressure and spray solvent through the airbrush for a short period.

Crown Cap

The crown cap (#1) is used to protect the needle when spraying a fine line and to prevent paint build-up and spitting when spraying large backgrounds.

Pre-Set Handle

The pre-set handle (#21) has a threaded adjusting knob (#23) on the back that limits the amount of the trigger pull back and needle movement. This controls the amount of paint being sprayed. Reference markers are on the knob.

CLEANING AND LUBRICATION

Before Each Spray Session

Spray the appropriate solvent or cleaner through the airbrush to make sure it is working properly.

To Clean Between Color Changes

Empty the excess paint left in the cup. Rinse the cup with solvent and use a paper towel to wipe out any left over paint. Fill the bottom of the cup with solvent and spray it through until the spray is clear. Fill with the next color.

After Each Spray Session

Increase the air pressure and spray cleaning solution through the airbrush. This will help thoroughly clean the paint passages, nozzle, and needle. Remove the needle and wipe it clean (see below).

Wipe down the outside of the airbrush with a solvent-dampened cloth, and soak the crown cap, if needed.

Do not soak the airbrush body in solvent unless the air valve has been disassembled and removed. The air valve o-ring could swell and cause air flow problems.

To Clean the Needle

Remove the back handle, loosen the needle locknut (#19), and remove the needle (#20). Using a soft cloth folded over the needle, wipe the residue off the needle by rotating it. Inspect the needle. If it is bent or mis-shapen, replace it.

Holding the trigger down, carefully re-insert the needle into the airbrush near the back and push gently until it seats against the nozzle and is visible through the tip. You should feel a slight resistance as the needle passes through the packing

(#6). If the needle stops suddenly, pull it out and check the trigger for proper positioning, then re-insert the needle. Release the trigger and tighten the needle locknut.

Lubrication

To insure smooth trigger action, periodically remove the needle and coat it with a high-quality lubricant (like DeVilbiss Spray Lube). Wipe the needle with a soft cloth, leaving it lightly coated. Re-insert the needle and re-tighten the needle locknut. Place a few drops of lube in the trigger slot in the airbrush body.

NOTE: Do not use WD-40 or light machine oil for lubrication, which will cause the needle to bind as it moves through the Teflon[®] packing. Do not over-lubricate the needle or the trigger. The excess lube could be pushed into the nozzle, causing paint flow problems.

REPLACEMENT PARTS AND ACCESSORIES

NOTE: If you must disassemble the airbrush, please do not use pliers. Tools are rarely needed. If needed,

however, use a small wrench to unscrew and lightly re-tighten the head cap (#3), which seats the nozzle on to the airbrush body. Do not overtighten!

Nozzle (#4)

If the nozzle becomes worn or damaged, it must be replaced. Before replacing the nozzle, protect the needle by pulling it back slightly. To do this, remove the handle (#21), loosen the needle locknut (#19), and carefully pull the needle back through the nozzle. Remove the head cap (#3) and pull out the nozzle. If it is stuck, loosen it by gently pushing the side of it with your thumb. Pull the nozzle off and replace it with the new one. Re-assemble the head cap and tighten it by hand or lightly with a wrench. Do not over tighten. Re-seat the needle into the nozzle by gently pushing it forward until it seats with the fluid nozzle. Tighten the needle locknut and continue reassembly.

NOTE: To insure even wear, change the needle at the same time as the nozzle.

Needle (#20)

DeVilbiss needles are made of precision machined stainless steel and are designed for long-term use. However, because of

their long tapers and very fine tips they can be easily damaged. If the needle point becomes bent or hooked, it should be straightened before being pulled back through the nozzle or the nozzle could become damaged. If the needle is not bent too badly, roll it between your finger and a smooth flat surface to straighten the point.

Quick Disconnect (Optional Accessory)

A quick disconnect stem is screwed on to each airbrush and a quick disconnect adapter is screwed on to the air hose. This allows for quick changes between airbrushes using one hose.

Hose

Use high quality, flexible DeVilbiss braided nylon air hose. Order DGR-123 (802769) 10' air hose assembly or DGR-124 (802770) 10' air hose assembly with quick disconnect.

TROUBLESHOOTING

CAUSE	CORRECTION	CAUSE	CORRECTION
Skipping: 1. Air pressure too high 2. Paint too thick 3. Airbrush is dirty 4. Nozzle not seated on body 5. Nozzle damaged or cracked 6. Dried paint on tip of needle 7. Nozzle not centered in air cap	1. Reduce pressure 2. Reduce with solvent 3. Refer to Cleaning in Maintenance Section 4. Tighten head cap (by hand or lightly with wrench) 5. Replace nozzle 6. Refer to "To Clean the Needle" 7. Clean nozzle & airbrush seats	Will Not Spray: 1. Clogged nozzle 2. Loose head cap 3. Loose needle locknut 4. Improper air pressure 5. Paint too thick 6. Nozzle damaged or cracked 7. Vent hole in cup lid is plugged	1. Refer to "Cleaning and Lubrication" 2. Tighten (by hand or lightly with wrench) 3. Tighten 4. Adjust 5. Reduce with solvent 6. Replace nozzle 7. Unplug with toothpick or brush
Spitting: 1. Dried paint on tip of needle 2. Airbrush is dirty 3. Paint too thick 4. Air pressure too low	1. Refer to "To Clean the Needle" 2. Refer to "Cleaning and Lubrication" 3. Reduce with solvent 4. Increase air pressure	Sprays Double Line: 1. Airbrush is dirty 2. Bent needle 3. Dirt on tip of nozzle or in air cap 4. Nozzle damaged or cracked 5. Dried paint on tip of needle	1. Refer to "Cleaning and Lubrication" 2. Replace or straighten needle 3. Flush with solvent or remove and soak parts 4. Replace nozzle 5. Refer to "To Clean the Needle"
Bubbling in cup 1. Loose head cap or nozzle not seated on body 2. Nozzle damaged or cracked	1. Tighten head cap (by hand or lightly with wrench) 2. Replace nozzle	Trigger sticks or does not move smoothly 1. Needs lubrication 2. Material leaked past packing	1. Refer to "Lubrication" 2. Thoroughly clean airbrush (including trigger) and tighten packing (#6) by inserting small slotted screwdriver into airbrush body until it contacts packing nut. Turn slightly clockwise.

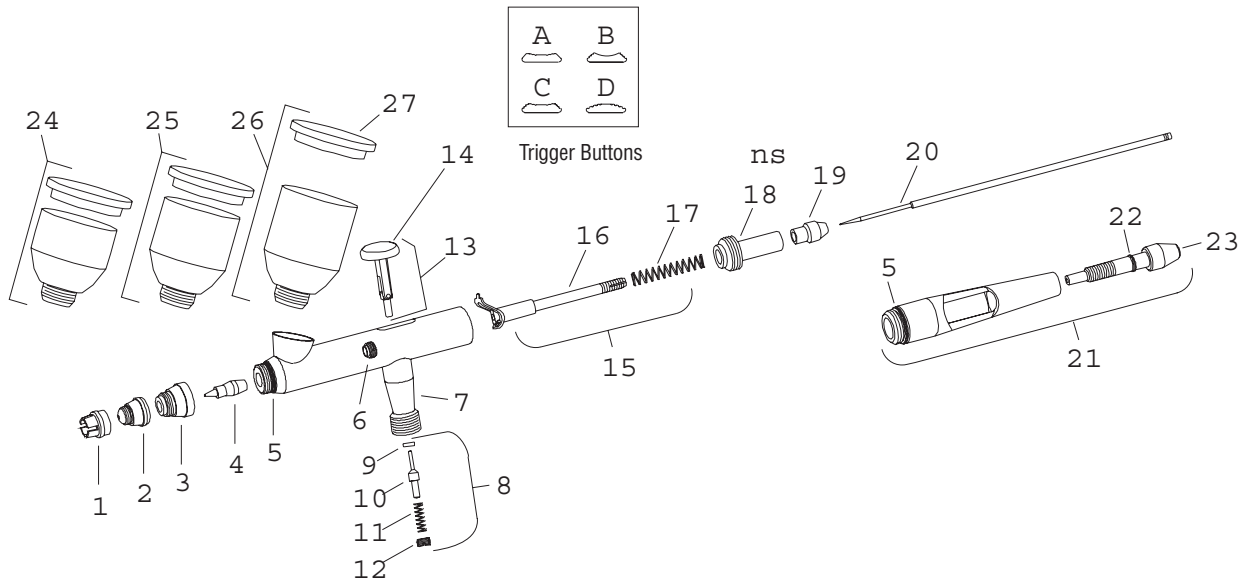

Ref. No.	Order No.	Model No.	Description
1	802613	DGR-101	Crown cap
2	802615	DGR-103-35	Air cap (for .35mm nozzle)
3	802616	DGR-104	Head cap
4	802618	DGR-105-35	Nozzle (.35mm)
• 5	–	–	O-ring (head cap & handle)
6	802619	DGR-106K	Packing and nut assembly (Teflon)
7	802620	DGR-107	Air valve casing
8	802621	DGR-108K	Air valve kit
• 9	–	–	Air valve washer
10	–	–	Air valve plunger
11	–	–	Air valve spring
12	–	–	Air valve nut
13	802622	DGR-109	Trigger assembly
14	802636	DGR-122K	Trigger buttons ergo-pack (4 types)
14a	–	–	Trigger button A (standard)
14b	–	–	Trigger button B
14c	–	–	Trigger button C
14d	–	–	Trigger button D

Ref. No.	Order No.	Model No.	Description
15	802623	DGR-110K	Needle guide, rocker, & spring
16	–	–	Needle guide and rocker
• 17	–	–	Needle spring
18	802624	DGR-111	Spring guide
19	802625	DGR-112	Needle locknut
20	802627	DGR-113-35	Needle (for .35mm nozzle)
21	802628	DGR-114	Cutaway handle w/pre-set
• 22	–	–	O-ring (pre-set needle knob)
23	802630	DGR-116	Pre-set needle knob
24	802631	DGR-117	1/4 oz.(7 cc) cup and lid
25	802632	DGR-118	1/3 oz.(9 cc) cup and lid (standard)
26	802633	DGR-119	1/2 oz.(14 cc) cup and lid
27	802634	DGR-120	Cup lid
28	802635	DGR-121K	DAGR repair kit
29	802974	DGR-12-K5	Air valve washer kit (5)
30	802975	DGR-18-K5	O-ring (head cap & handle) kit (5)

• **DAGR Repair Kit 802635 (DGR-121K) includes:**

Ref.	Description	Qty.
5	O-ring (head cap & handle)	3
9	Air valve washer	2
17	Needle spring	1
22	O-ring (pre-set needle knob)	1

WARNING

The following hazards may occur during the normal use of this equipment. Please read the following warnings before using this equipment.

**HAZARD: FIRE**

CAUSE: Solvent and coatings can be highly flammable or combustible especially when sprayed.

SAFEGUARDS: Adequate exhaust must be provided to keep air free of accumulations of flammable vapors.

Smoking must never be allowed in the spray area.

Fire extinguishing equipment must be present in the spray area.

**HAZARD: SOLVENT SPRAY**

CAUSE: During use and while cleaning and flushing, solvents can be forcefully expelled from fluid and air passages. Some solvents can cause eye injury.

SAFEGUARDS: Wear eye protection.

**HAZARD: INHALING TOXIC SUBSTANCES**

CAUSE: Certain materials may be harmful if inhaled, or if there is contact with the skin.

SAFEGUARDS: Follow the requirements of the Material Safety Data Sheet supplied by your coating material manufacturer.

Adequate exhaust must be provided to keep the air free of accumulations of toxic materials.

Use a mask or respirator whenever there is a chance of inhaling sprayed materials. The mask must be compatible with the material being sprayed and its concentration. Equipment must be as prescribed by an industrial hygienist or safety expert, and be NIOSH approved.

**HAZARD: EXPLOSION HAZARD
– INCOMPATIBLE MATERIALS**

CAUSE: Halogenated hydrocarbon solvents – for example; methylene chloride and 1,1,1, – Trichloroethane are not chemically compatible with the aluminum that might be used in many system components. The chemical reaction caused by these solvents reacting with aluminum can become violent and lead to an equipment explosion.

SAFEGUARDS: Guns with stainless steel internal passageways may be used with these solvents. However, aluminum is widely used in other spray application equipment – such as material pumps, regulators, valves, and this gun and cup. Check all equipment

items before use and make sure they can also be used safely with these solvents. Read the label or data sheet for the material you intend to spray. If in doubt as to whether or not a coating or cleaning material is compatible, contact your material supplier.

HAZARD: GENERAL SAFETY

CAUSE: Improper operation or maintenance of equipment.

SAFEGUARDS: Operators should be given adequate training in the safe use and maintenance of the equipment (in accordance with the requirements of NFPA-33, Chapter 15). Users must comply with all local and national codes of practice and insurance company requirements governing ventilation, fire precautions, operation, maintenance, and housekeeping. These are OSHA Sections 1910.94 and 1910.107 and NFPA-33.

HAZARD: CUMULATIVE TRAUMA DISORDERS ("CTD'S")

CTD's, or musculoskeletal disorders, involve damage to the hands, wrists, elbows, shoulders, neck, and back. Carpal tunnel syndrome and tendonitis (such as tennis elbow or rotator cuff syndrome) are examples of CTD's.

CAUSE: Use of hand tools may cause cumulative trauma disorders ("CTD's").

CTD's, when using hand tools, tend to affect the upper extremities. Factors which may increase the risk of developing a CTD include:

1. High frequency of the activity.
2. Excessive force, such as gripping, pinching, or pressing with the hands and fingers.
3. Extreme or awkward finger, wrist, or arm positions.
4. Excessive duration of the activity.
5. Tool vibration.
6. Repeated pressure on a body part.
7. Working in cold temperatures.

CTD's can also be caused by such activities as sewing, golf, tennis, and bowling, to name a few.

SAFEGUARDS: Pain, tingling, or numbness in the shoulder, forearm, wrist, hands, or fingers, especially during the night, may be early symptoms of a CTD. Do not ignore them. Should you experience any such symptoms, see a physician immediately. Other early symptoms may include vague discomfort in the hand, loss of manual dexterity, and nonspecific pain in the arm. Ignoring early symptoms and continued repetitive use of the arm, wrist, and hand can lead to serious disability. Risk is reduced by avoiding or lessening factors 1-7.

This product is covered by DeVilbiss' 1-year Limited Warranty

DEVILBISS[®]
AUTOMOTIVE REFINISHING

1724 Indian Wood Circle, Suite J-K, Maumee, OH 43537
Toll-Free Telephone: 800.445.3988 (U.S.A. and Canada)
Toll-Free FAX: 800.445.6643 Email: askus@itwar.com
www.autorefinishdevilbiss.com

Ringwood Road, Bournemouth BH11 9LH England
Tel: +44 (0) 1202 571111 Fax: +44 (0) 1202 573488
Email: auto-refinish@itwfinishing.co.uk
www.devilbisseu.com

EC Declaration of Conformity

We, DeVilbiss Automotive Refinishing, 1724 Indian Wood Circle, Suite J-K, Maumee, Ohio 43537, USA, as the representative/manufacturer of the item listed: Airbrush model DGR-501G, declare, under our sole responsibility, that the equipment to which this document relates is in conformity with the following standards or other normative documents:

BS EN 292-1 parts 1 and 2: 1991, BS EN 1953: 1999, EN 13463-1:2001,

And thereby conforms to the protection requirements of Council Directive 89/392/EEC relating to Machinery Safety Directive and Council Directive 94/9/EC relating to Equipment and Protective Systems intended for use in Potentially Explosive Atmospheres protection level II 2 G.

A handwritten signature in black ink, appearing to read 'Tom White', written in a cursive style.

Thomas R. White, General Manager

October 26, 2007